

# e945

Bedienungsanleitung  
Instructions for use  
Notice d'emploi  
Istruzioni per l'uso  
Instrucciones para el uso  
Gebruiksaanwijzing

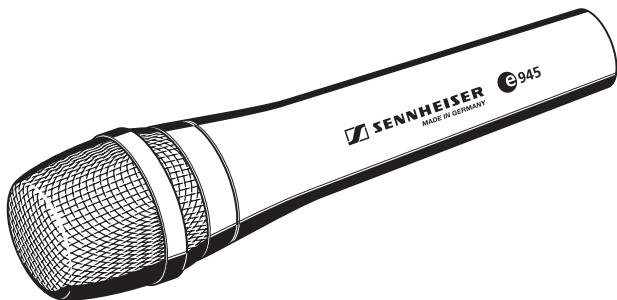

Bedienungsanleitung.....	3
Instructions for use .....	9
Notice d'emploi .....	15
Istruzioni per l'uso.....	21
Instrucciones para el uso.....	27
Gebruiksaanwijzing.....	33

## **e945**

Hochwertiges dynamisches Mikrofon mit Supernierencharakteristik. Durch die Charakteristik besonders rückkopplungsarm. Hoher Nahbesprechungseffekt.

### **Merkmale**

- einzigartige Feedback-Sicherheit
- extrem robust für den rauen Bühnenalltag
- um 3–6 dB besseres „Gain before Feedback“
- durchsetzungsfähiger, druckvoller Sound bei Vocals
- enorm lebendiger Sound bei Drums und Percussions
- integriertes Shock-mount

### **Lieferumfang**

Mikrofon **e945**

Klammer MZQ 800 Art.-Nr. 4711

Tasche

Bedienungsanleitung

Garantiekarte

# Besprechen

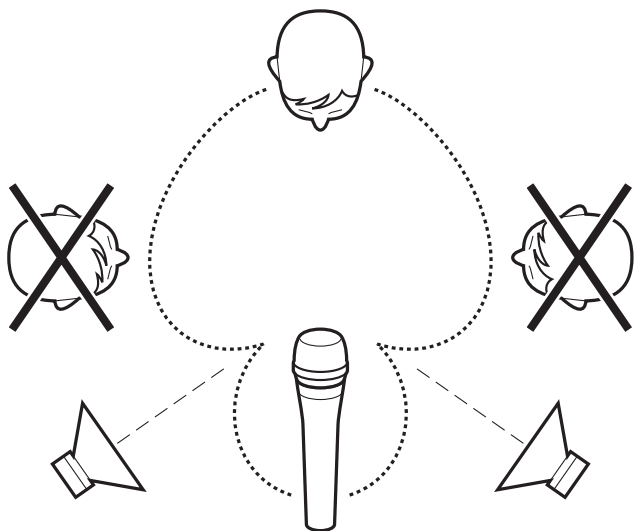

## Mikrofonanschluss

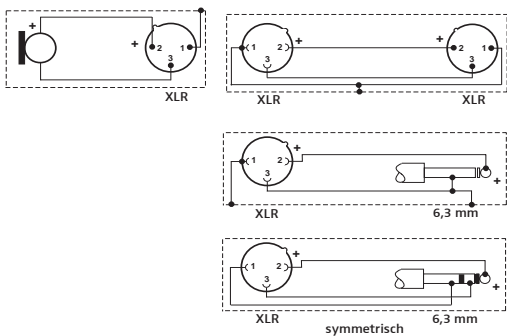
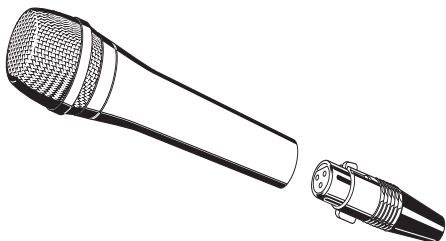

## Einsprachekorb abdrehen

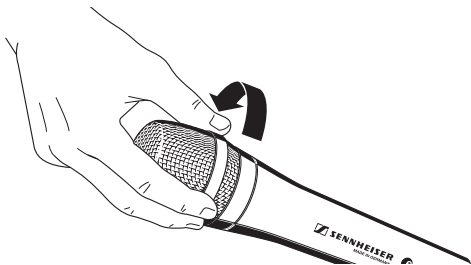

## Technische Daten

Wandlerprinzip	dynamisch
Akustische Arbeitsweise	Druckgradientenempfänger
Übertragungsbereich	40–18.000 Hz
Richtcharakteristik	Superniere
Freifeldleerlauf- Übertragungsfaktor (bei 1 kHz)	2,0 mV/Pa $\pm$ 3 dB
Magnetfeldstörfaktor (bei 50 Hz)	$\leq 1\mu\text{V}/\mu\text{T}$
Nennimpedanz (bei 1 kHz)	350 $\Omega$
Min. Abschlussimpedanz	1 k $\Omega$
Rückwärtsdämpfung (bei 1 kHz und 120°)	> 20 dB
Stecker	3-polig XLR-3-Stecker
Gewicht	365 g
Maße	$\varnothing$ 46,6 mm, Länge 186 mm

# Übersicht Mikrofonanwendungen

Anwendung	Modell											
	e901	e902	e904	e905	e906	e908B	e908B ew	e908D	e908T ew	e914	e935	e945
Gesang											x	x
Chor										x		
Studio, akust. Instrumente					x					x		
Orchester										x		
Trompete, Posaune			x			x			x			
Saxophon			x			x	x					
Akustische Gitarre										x		
Akustischer Bass										x		
Gitarrenverstärker					x							
Bassverstärker		x										
Leslie	x	x	x	x								
Piano, Flügel										x		
Kick Drum	x	x										
Snare Drum			x	x	x			x				
Hänge-Tom			x	x	x	x		x				
Stand-Tom		x	x	x	x			x				
Congas			x		x	x		x				
Becken										x		
Percussion			x	x	x	x		x		x		
Overhead										x		





## **e945**

High-quality dynamic microphone with super-cardioid pick-up pattern. Exceptional feedback rejection. High proximity effect.

### **Features**

- Exceptional feedback rejection
- Extremely rugged for rough stage use
- “Gain before feedback” increased by 3-6 dB
- Powerful sound with presence boost for improved sound projection
- Extremely vivid, crisp sound with drums and percussions
- Integral shock mount

### **Delivery includes**

e945 microphone

MZQ 800 microphone clamp Cat. No. 4711

Pouch

Instruction manual

Guarantee Certificate

## Sound pick-up

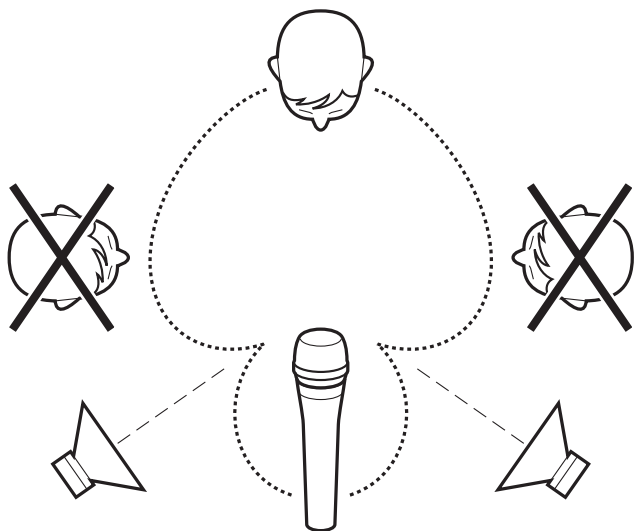

## Connection details

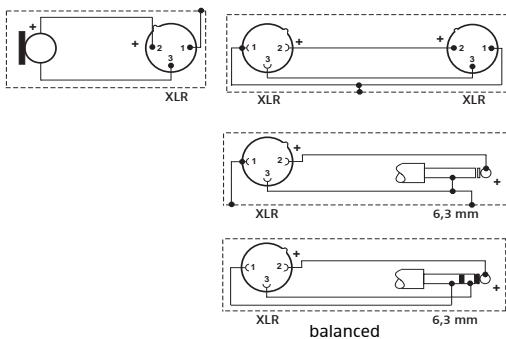
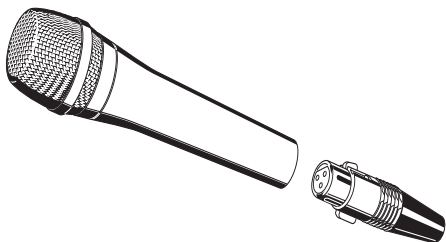

## Removing the sound inlet basket

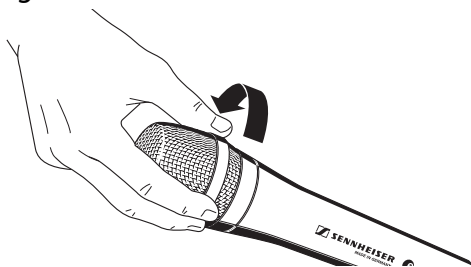

## Specifications

Transducer principle	dynamic
Acoustic operating principle	pressure gradient receiver
Frequency response	40–18,000 Hz
Pick-up pattern	super-cardioid
Sensitivity (free field, no load) (at 1 kHz)	2.0 mV/Pa $\pm$ 3 dB
Magnetic field interference factor (at 50 Hz)	$\leq 1\mu\text{V}/\mu\text{T}$
Nominal impedance (at 1 kHz)	350 $\Omega$
Min. terminating impedance	1 k $\Omega$
Front-to-back rejection (at 1 kHz and 120°)	> 20 dB
Connector	XLR-3
Weight	365 g
Dimensions	diameter: 46.6 mm, length: 186 mm

## Overview of microphone applications

Application	Variant											
	e901	e902	e904	e905	e906	e908B	e908B ew	e908D	e908T ew	e914	e935	e945
Vocals											x	x
Choir										x		
Studio, acoustic instruments					x					x		
Orchestra										x		
Trumpets, Trombones			x			x			x			
Saxophone			x			x	x					
Acoustic guitar										x		
Acoustic bass										x		
Guitar amplifiers					x							
Bass amplifiers		x										
Leslie	x	x	x	x								
Piano, grand piano										x		
Kick Drum	x	x										
Snare Drum			x	x	x			x				
Rack toms			x	x	x	x		x				
Floor toms		x	x	x	x			x				
Congas			x		x	x		x				
Cymbals										x		
Percussion			x	x	x	x		x		x		
Overhead										x		



## 945

Microphone dynamique de haute qualité, de directivité supercardioïde, assurant une exceptionnelle réjection du Larsen. Effet de proximité prononcé.

### Points forts

- Exceptionnelle réjection du Larsen
- Très grande robustesse, pour résister aux rigueurs des concerts
- « Gain avant Larsen » accru de 3 à 6 dB
- Son d'une grande puissance, avec une bosse de présence améliorant la projection sur les voix
- Son très vivant sur la batterie et les percussions
- Suspension élastique intégrée

### L'emballage contient

Microphone  945

Pince MZQ 800 N° Réf. 4711

Etui

Notice d'emploi

Document de garantie

## Directivité – zone de couverture

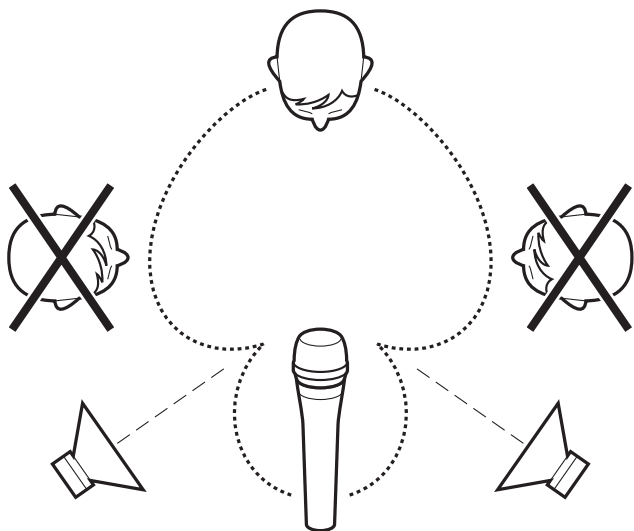



## Connexion du microphone

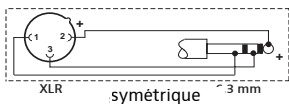
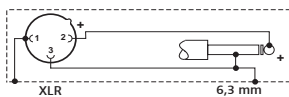
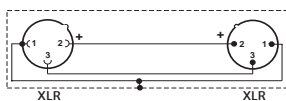
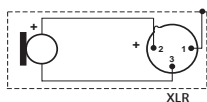
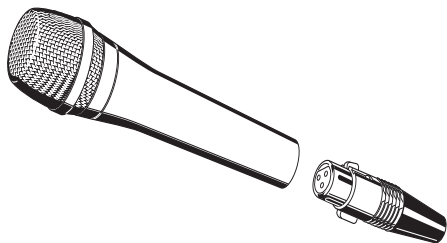

## Démontage de la tête de microphone

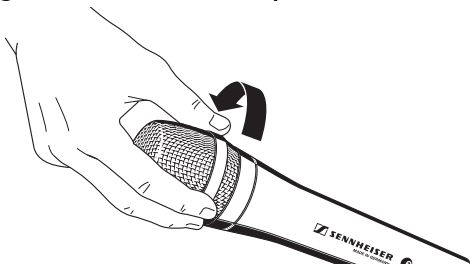

## Caractéristiques techniques

Principe transducteur	dynamique
Principe acoustique de fonctionnement	gradient de pression
Réponse en fréquence	40–18.000 Hz
Directivité	super-cardioïde
Sensibilité (champ libre, à vide) (à 1 kHz)	2,0 mV/Pa $\pm$ 3 dB
Sensibilité aux champs magnétiques (à 50 Hz)	$\leq 1\mu\text{V}/\mu\text{T}$
Impédance nominale (à 1 kHz)	350 $\Omega$
Impédance de charge minimale	1 k $\Omega$
Réjection arrière (à 1 kHz et 120°)	> 20 dB
Connecteur	XLR-3, 3 contacts
Poids	365 g
Dimensions	diamètre : 46,6 mm, longueur : 186 mm

## Vue d'ensemble des applications de microphones

Application	Modèle											
	e901	e902	e904	e905	e906	e908B	e908B ew	e908D	e908T ew	e914	e935	e945
Chant											x	x
Chœurs										x		
Studio, instruments acoustiques					x					x		
Orchestre										x		
Trompette, Trombone			x			x			x			
Saxophone			x			x	x					
Guitare acoustique										x		
Basse acoustique										x		
Ampli de guitare					x							
Ampli de basse		x										
Leslie	x	x	x	x								
Piano, à queue										x		
Grosse caisse	x	x										
Caisse claire			x	x	x			x				
Tom suspendu			x	x	x	x		x				
Tom sur pied		x	x	x	x			x				
Congas			x		x	x		x				
Cymbale										x		
Percussions			x	x	x	x		x		x		
Overhead										x		



## **€945**

Microfono dinamico supercardioide di qualità elevata. Ottime proprietà anti-larsen. Effetto di prossimità elevato.

### **Caratteristiche**

- straordinaria protezione contro il feedback
- massima robustezza per il duro lavoro quotidiano sul palco
- "Gain before Feedback" migliorato di 3–6 dB
- suono potente e intenso per il canto
- suono estremamente realistico e percussivo con batteria e percussioni
- schockmount integrato

### **Dotazione di fornitura**

Microfono €945

Dispositivo di fissaggio MZQ 800 N. art. 4711

Custodia

Istruzioni per l'uso

Scheda di garanzia

## Raggio di azione

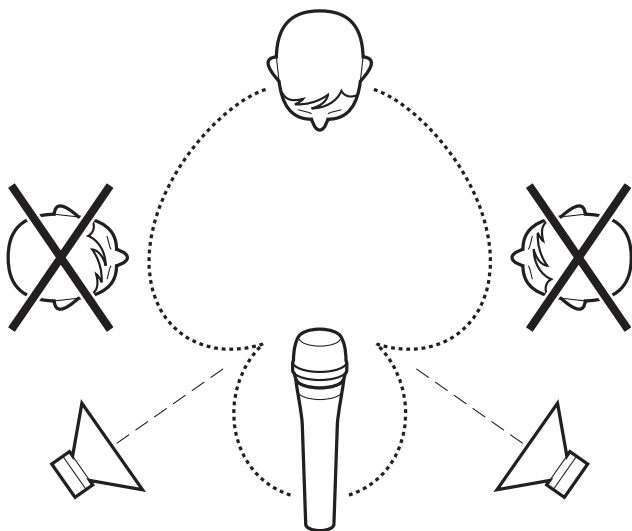

## Collegamento del microfono

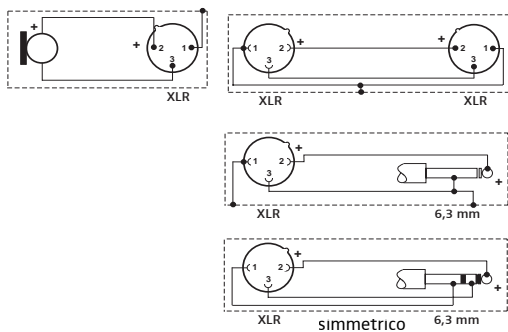
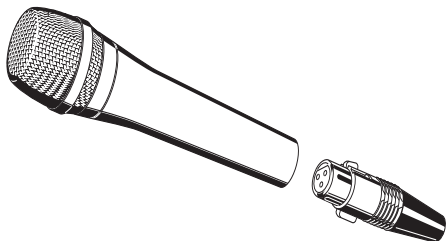

## Svitare la testa del microfono

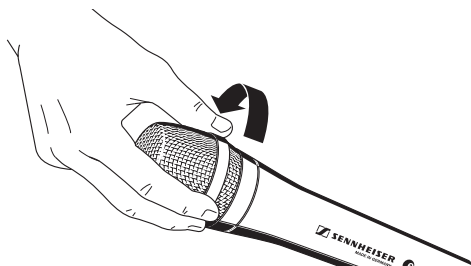

## Dati tecnici

Principio di funzionamento	dinamico
Principio di funzionamento	a gradiente di pressione
Risposta in frequenza	40–18.000 Hz
Direttività	supercardioide
Sensibilità (in campo libero, senza carico) ad 1 kHz	2,0 mV/Pa $\pm$ 3 dB
Sensibilità ai campi magnetici (a 50 Hz)	$\leq 1\mu\text{V}/\mu\text{T}$
Impedenza nominale (ad 1 kHz)	350 $\Omega$
Impedenza minima di carico	1 k $\Omega$
Attenuazione avanti/indietro (ad 1 kHz e 120°)	> 20 dB
Connettore	connettore XLR-3 a 3 poli
Peso	365 g
Dimensioni	$\varnothing$ 46,6 mm, lunghezza 186 mm



## Panoramica degli utilizzi del microfono

Utilizzo	Modello											
	e901	e902	e904	e905	e906	e908B	e908B ew	e908D	e908T ew	e914	e935	e945
Canto											x	x
Coro										x		
Studio, strumenti acustici					x					x		
Orchestra										x		
Tromba, Trombone			x			x		x				
Sassofono			x			x	x					
Chitarra acustica										x		
Basso acustico										x		
Amplificatore per chitarra					x							
Amplificatore per basso		x										
Leslie	x	x	x	x								
Piano, pianoforte a coda										x		
Kick Drum (tamburo a cornice)	x	x										
Snare Drum (cassa chiara)			x	x	x			x				
Tom sospesi			x	x	x	x		x				
Tom a terra		x	x	x	x			x				
Conga			x		x	x		x				
Piatti										x		
Percussioni			x	x	x	x		x		x		
Overhead										x		



## **e945**

Micrófono dinámico de alta calidad con característica supercardioide. Gracias a su característica, especialmente pobre en reacoplamientos. Elevado efecto anteboca.

### **Características**

- extraordinaria seguridad contra el reacoplamiento
- extremadamente robusto para el uso duro en el escenario
- "Gain before Feedback" mejorado en 3–6 dB
- sonido potente y pleno para voz
- sonido percusivo enormemente vivo en baterías e instrumentos de percusión
- montado a prueba de sacudidas

### **Volumen de suministro**

Micrófono **e945**

Pinza MZQ 800 nº art. 4711

Bolsa

Instrucciones para el uso

Tarjeta de garantía

# Hablar

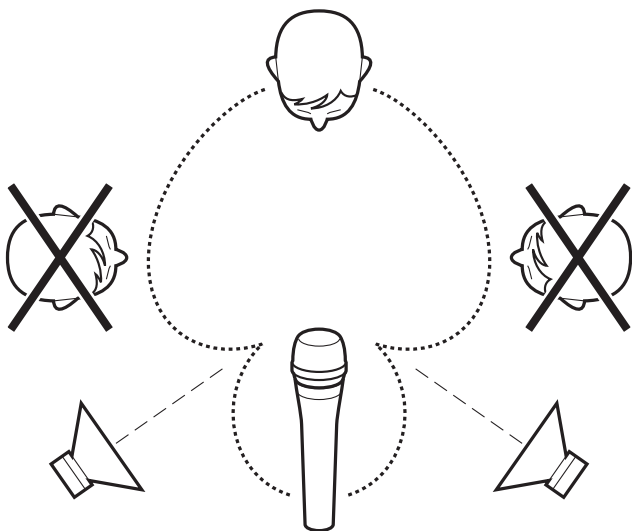

## Conexión de micrófono

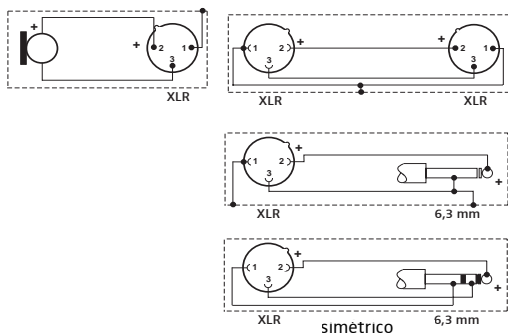
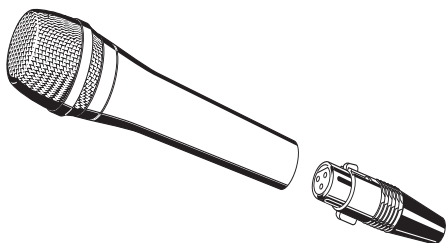

## Desmontaje de cesto de registro

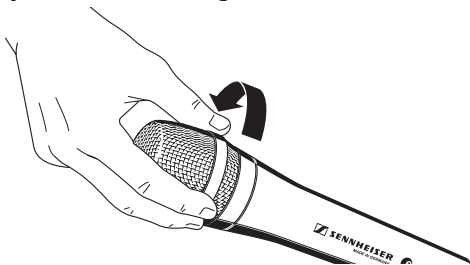

## Datos técnicos

Principio transductor	dinámico
Modo acústico	Receptor de gradiente de presión
Respuesta	40–18.000 Hz
Característica direccional	supercardioide
Factor de transmisión neutro en campo libre (con 1 kHz)	2,0 mV/Pa $\pm$ 3 dB
Factor de interferencia de campo magnético (con 50 Hz)	$\leq 1\mu\text{V}/\mu\text{T}$
Impedancia nominal (con 1 kHz)	350 $\Omega$
Impedancia terminal mín.	1 k $\Omega$
Atenuación inversa (con 1 kHz y 120°)	> 20 dB
Conector	Conector XLR-3 de 3 polos
Peso	365 g
Dimensiones	$\varnothing$ 46,6 mm, largo 186 mm

## Vista general de las aplicaciones del micrófono

Aplicación \ Modelo	Modelo											
	e901	e902	e904	e905	e906	e908B	e908B ew	e908D	e908T ew	e914	e935	e945
Canto											x	x
Coros										x		
Estudio, instrumentos acústicos					x					x		
Orquesta										x		
Trompeta, Trombón			x			x			x			
Saxofón			x			x	x					
Guitarra acústica										x		
Bajo acústico										x		
Amplificador de guitarra					x							
Amplificador de bajo		x										
Leslie	x	x	x	x								
Piano, piano de cola										x		
Kick Drum	x	x										
Snare Drum			x	x	x			x				
Tam-tam suspendido			x	x	x	x		x				
Tam-tam con pie		x	x	x	x			x				
Congas			x		x	x		x				
Platillos										x		
Percusión			x	x	x	x		x		x		
Overhead										x		





Hoogwaardige dynamische microfoon met supernierkarakteristiek. Zeer ongevoelig voor rondzingen. Vol stemgeluid bij spreken op korte afstand.

## Eigenschappen

- unieke feedback-betrouwbaarheid
- extreem robuust t.b.v. de meest zware podiumomstandigheden
- met 3 – 6 dB verhoogde “Gain voor Feedback”
- krachtig, indrukwekkend geluid voor zangtoepassing
- enorm levendig geluid bij drums en percussie-instrumenten
- geïntegreerde verende ophanging

## Omvang levering

Microfoon  e945

Klem MZQ 800 Art.-Nr. 4711

Hoes

Gebruiksaanwijzing

Garantiebewijs

# Vergaderen

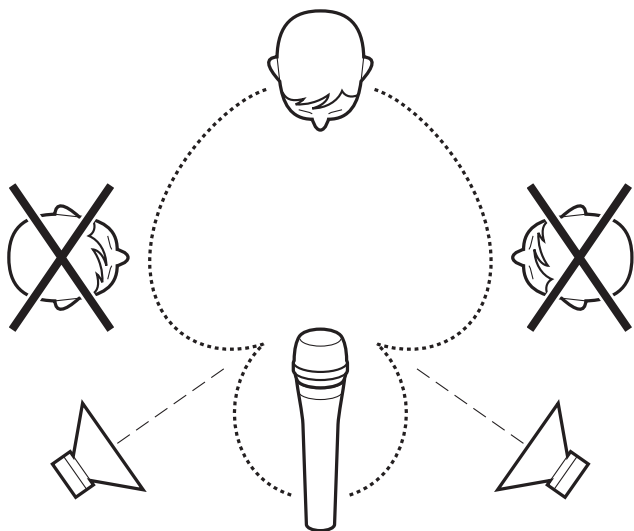

## Microfoonaansluiting

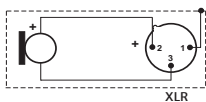
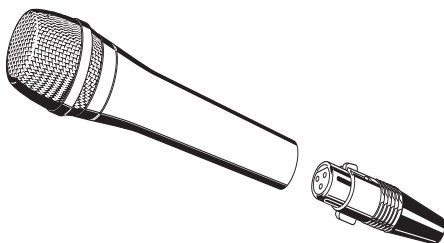

XLR

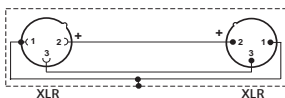

XLR

XLR

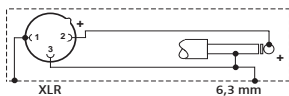

XLR

6,3 mm

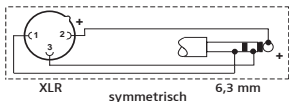

XLR

symmetrisch

6,3 mm

## Spreekorf losdraaien

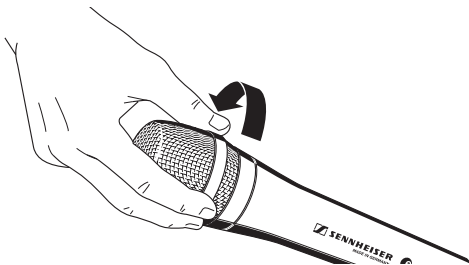

## Technische gegevens

Omvormerprincipe	dynamisch
Akoestische werking	drukgradiënt
Frequentiebereik	40–18.000 Hz
Richtkarakteristiek	Supernier
Onbelaste werking	
Frequentiefactor veld (bij 1 kHz)	2,0 mV/Pa ± 3 dB
Storingsfactor magneetveld (bij 50 Hz)	≤ 1μV/μT
Nom. impedantie (bij 1 kHz)	350 Ω
Min. afsluitimpedantie	1 kΩ
Achterwaartse demping (bij 1 kHz en 120°)	> 20 dB
Stekker	3-polige XLR-3-stekker
Gewicht	365 g
Afmeting	Ø 46,6 mm, lengte 186 mm

## Overzicht van microfoontoepassingen

Toepassing	Model											
	e901	e902	e904	e905	e906	e908B	e908B ew	e908D	e908T ew	e914	e935	e945
Zang											x	x
Koor										x		
Studio, akoest. instrumenten					x					x		
Orkesten										x		
Trompet, Trombone			x			x			x			
Saxofoons			x			x	x					
Akoest. gitaren										x		
Akoestische bas										x		
Gitaarversterker					x							
Basversterker		x										
Leslie	x	x	x	x								
Piano, vleugel										x		
Kick Drum	x	x										
Snare Drum			x	x	x			x				
Hangende tom			x	x	x	x		x				
Staande tom		x	x	x	x			x				
Conga's			x		x	x		x				
Bekken										x		
Percussie			x	x	x	x		x		x		
Overhead										x		

Soll-Frequenzgang  
 Nominal Frequency response  
 Courbe de réponse  
 Risposta armonica nominale  
 Respuesta nominal  
 Streefwaarde-Frequentiekarakteristiek

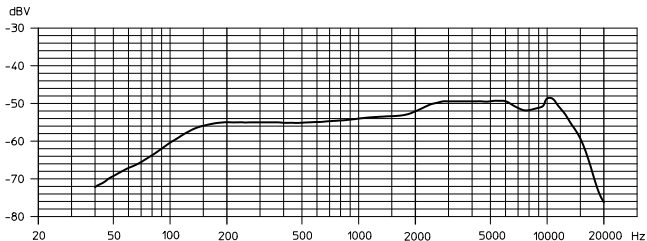

Polardiagramm  
 Pick-up pattern  
 Diagramme de la directivité  
 Diagramma polare  
 Diagrama de la directividad  
 Polardiagram

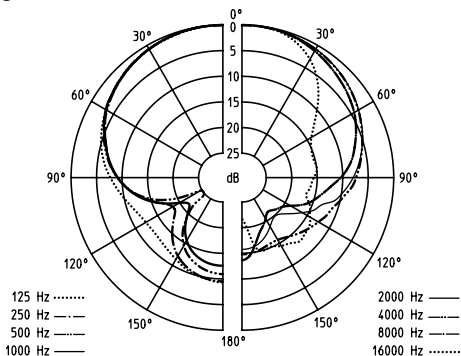



### Konformitätserklärung

Sennheiser electronic GmbH & Co. KG erklären, dass dieses Gerät die anwendbaren CE-Normen und Vorschriften erfüllt.

### Approval

Sennheiser electronic GmbH & Co. KG declare that this device is in compliance with the applicable CE standards and regulations.

### Certification

Sennheiser electronic GmbH & Co. KG déclarons que cet appareil est en conformité avec les normes CE.

### Certificazione

Sennheiser electronic GmbH & Co. KG dichiara che questo apparecchio risponde alle normative e alle prescrizioni CE applicabili.

### Autorización

Sennheiser electronic GmbH & Co. KG declara que este aparato cumple las normas y directrices de la CE aplicables.

### Vergunning

Sennheiser electronic GmbH & Co. KG verklaren, dat dit toestel voldoet aan de toepasselijke CE-normen en voorschriften.

**Diese Service-Nummer gilt nur für Deutschland**



**K.I.S.S.**

Kunden-Information-System-Sennheiser

**0180 / 5221 539**

0,12 € je Minute

Montag - Freitag: 8.00 Uhr - 18.00 Uhr



Sennheiser electronic GmbH & Co. KG  
30900 Wedemark, Germany  
Phone +49 (5130) 600 0  
Fax +49 (5130) 600 300  
[www.sennheiser.com](http://www.sennheiser.com)  
Printed in Germany

Publ. 04/05

89059/A02